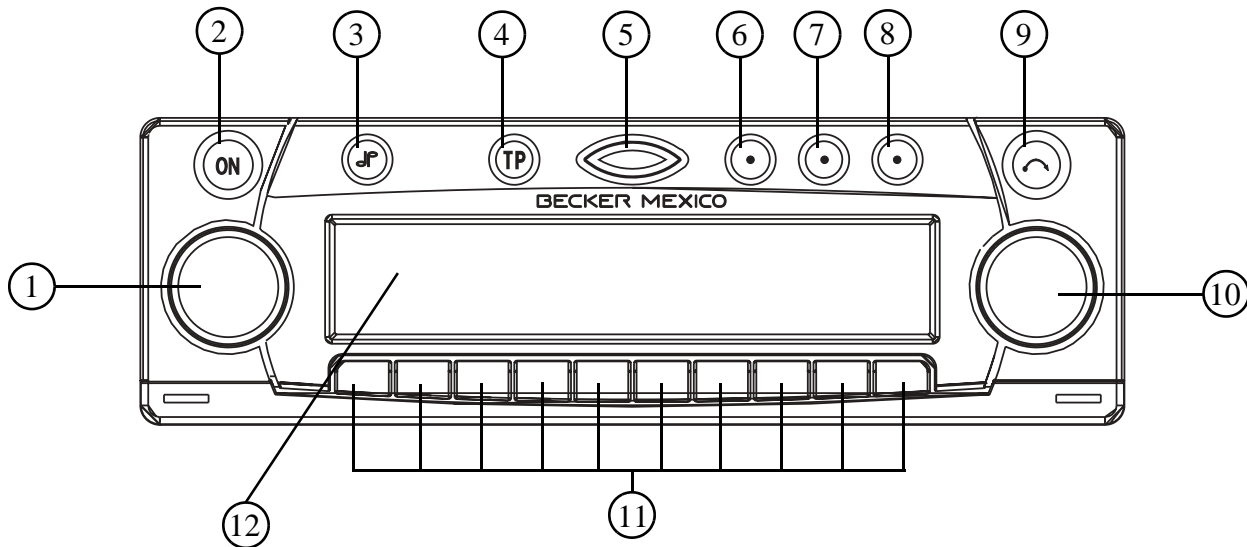

Table of Content	49		60
Arrangement of Controls	51	Scan search	61
Anti-theft Device	52	Direct frequency entry for FM	61
Code number entry	52	Direct frequency entry for AM, LW, SW	61
Remove portable panel	53	Programme type selection (PTY)	61
Inserting portable panel	53	Switching PTY display on / off	61
General Operation	54	Requesting/storing stations on FM STT	62
Switch on / off	54	Requesting/storing AM, LW, SW stations	62
Adjust volume	54	AM, LW, SW autostore	63
Mute function	54	FM manual tuning	63
Activate tone menu	54	AM, LW, SW manual tuning	63
Adjust bass	55	Regionalisation	64
Adjust treble	55	Switching regionalisation on / off	64
Adjust balance	55	Switching frequency display on / off	65
Fader	55	Switching radio text display on / off	65
Loudness on /off	56	Programme filtering	66
Linear adjustment	56	Deactivating the programme filter	66
Subwoofer output volume	56	Traffic Program (TP)	67
Selecting reception optimisation	57	Activating/quitting the TP menu	68
Radio Operation	58	Setting automatic tracking	68
Selecting the operating mode	58	Setting/deleting direct programming	68
Selecting the waveband	58	Switching off TP	69
Switching on radio menu mode	58	Mute function - switch on/off	69
Setting procedures for transmitter selection	59	Interrupting TP announcements	69
Dynamic autostore (FM DAS)	59	TP announcement volume	69
FM transmitter search	60	Telephone mute function	70
AM, LW, SW station search	60	Time request	70
		Tape Operation	71
		Cassettes - insert / eject	71
		Track switching	71

Table of Content

Radio operation during forward / rewind	71	Setting the search mode (SEK)	83
Fast forward / rewind	72	GAL setting	83
Music search - forwards / backwards	72	Telephone mute characteristics (TEL)	84
Dolby NR	72	Setting right-hand or left-hand drive (DRV)	84
Skip blank	73	(COL) display colour setting (not for 4625)	84
Scan search	73	Favourite station settings (FAV)	85
Cleaning the cassette mechanism	73	AUX input (AUX)	85
CD/MD Operation	74	Display setting (LCD) (not for 4625)	86
Compact disc (CD) instructions	74	Service Menu	87
Insert / ejecting CDs/MDs	74	Remote Control (option)	88
Skipping tracks - forwards / backwards	75	Connection Instructions	89
Scan search	75	Removal / Installation Guide	90
Fast forward / rewind	75	General Instructions	92
Number of tracks and total playing time	76	Frequency search	92
Random play	76	Name search	92
Replaying a track (repeat)	76	Transmitter chain search	92
Direct track selection	77	RDS SYSTEM	92
Temperature protection circuit	77	PTY (Program Type)	93
CD/MD Changer Operation	78	Technical Data	94
Operational readiness of CD/MD changer	78	NOTICE	95
CD magazine - load / unload	78		
Playing CDs/MDs	79		
Naming a CD	80		
CD title filtering	81		
User Menu	82	DOLBY and the double D-symbol  are trademarks of Dolby Laboratories Licensing Corporation.	
Requesting/quitting user menu	82	Dolby noise reduction system manufactured under license from Dolby Laboratories Licensing Corporation.	
User memory (US)	82		

Arrangement of Controls



- 1 Volume control
- 2 On / off switch (ON)
- 3 Tone button (T)
- 4 Road traffic announcement button (TP)
- 5 Infrared receiver
- 6 Function button 1.
- 7 Function button 2.
- 8 Function button 3.

- 9 CD/MD eject button (Eject)
- 10 Right rotary control
- 11 Multifunction buttons
- 12 Display

Anti-theft Device

Code number entry

If the car radio is disconnected from the power supply, it is theft-protected upon reconnection. After switching on at the **ON** button, the prompt **CODE**, followed by 4 squares is displayed.

The four-digit code must then be entered using the multifunction buttons “1-0”.

Example: Code number 1530 (the code number can be found on the enclosed CODE CARD).

Enter code number using the multifunction buttons.

The first square is extinguished after entry of the first digit. The second square is extinguished after entry of the second digit, etc. The unit switches on automatically after entry of the 4th digit, if this and all other digits have been correctly entered.

Note: It is essential that the CODE CARD be kept in a safe place outside the vehicle. Thus, illegal use is not possible. The accompanying sticker should be attached to the inside of the vehicle windscreen/window.

If an incorrect code number is entered, the prompt **CODE** with the four stars is displayed again. After entering incorrect code three times **WAIT** is displayed and the unit is disabled for approx. 60 minutes. Three further incorrect entries block the unit again for 60 minutes.

Important: The waiting time functions only with the unit switched on.

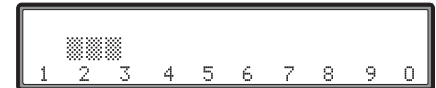
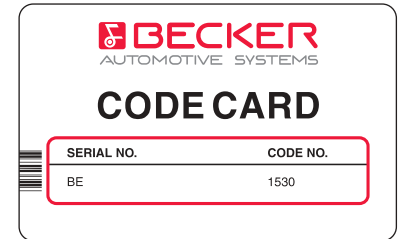
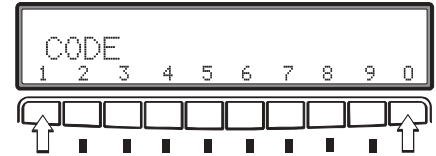

Remove portable panel

As effective anti-theft device, the portable panel (A) can be removed from the unit.

Press and hold button  (storage medium remains in the unit). The display folds forwards.

The portable component can then be pulled out.

The volume is limited to a maximum value after the display has been folded down. After 20 seconds an audible signal indicates that the control component is folded down. The unit is switched to mute. The unit switches off after an additional 10 seconds.

Note: For safety reasons, it is not permitted to leave the portable panel open when driving

Important: Please insert the portable panel in the accompanying protective cover after removal.

Do not touch the metal contacts on the portable panel or on the radio.

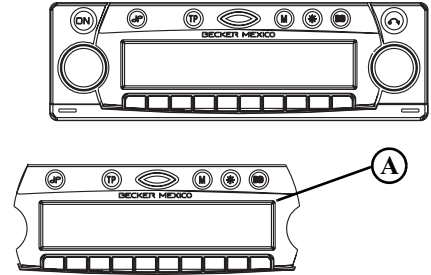

Inserting portable panel

Insert the portable panel so that it engages first in the lower left catch and then in the lower right. Then press the portable panel into the upper catches.

Or position portable panel directly over all four catches and press in firmly to engage.

For proper functioning, ensure that the portable panel is firmly engaged in all four catches.

If a new portable panel or one from another unit is utilised, the code number must be entered, as previously described, in order to activate the unit.

General Operation

Switch on / off

Press **ON** button.

Further on / off switching possibilities: Via ignition. In order to switch on via the ignition, the unit must previously have been switched off via the ignition. After switching off the ignition, the unit can be prevented from switching off by pressing the **ON** button within 3 seconds.

Note : The unit can also be switched on with the ignition switched off via the **ON** button, but will switch off automatically after 1 hour.

Adjust volume

Turn volume control to right / left. The volume is increased or decreased. The current volume level is shown on the display.



Mute function

The unit can be switched to mute in each operating mode by pressing the volume control. In the display **MUTE** or **TP INFO** (page 69) will appear. The mute function is cancelled by pressing the volume control, changing the operating mode, changing the waveband or inserting MD/CD or TAPE.



Activate tone menu

Press **F** button. The tone menu is activated. The following functions can be called up: **BASS** (Bass), **TREB** (Treble), **BAL** (Balance), **FAD** (Fader), **LOUD** (Loudness) and **STEREO** (Reception optimisation).

Bass and treble settings for the AM, FM wavebands, for road traffic announcements and MD/CD/TAPE and CDC/MDC operation are stored separately. The settings for fader, balance and loudness are stored together for all operating modes.



Adjust bass

Press  button and then multifunction button (under **BASS**) “-” or “+”. Set the desired bass via both buttons.

Centre setting: Press both buttons simultaneously.

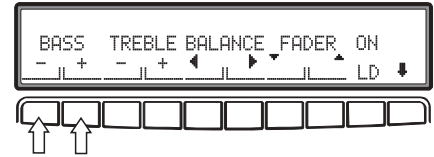

Adjust treble

Press  button and then multifunction button (under **TREBLE**) “-” or “+”. Set the desired treble via both buttons.

Centre setting: Press both buttons simultaneously.

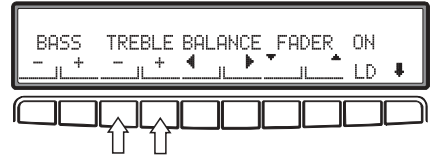

Adjust balance

Press  button and then multifunction button “◀” or “▶”. Set the desired balance via both buttons.

Centre setting: Press both buttons simultaneously.

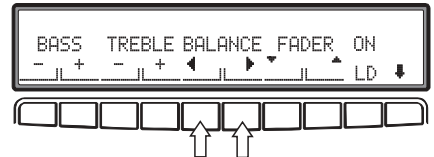

Fader

Press  button and then multifunction button “▼” or “▲”. Set the desired fade level via both buttons.

Centre setting: Press both buttons simultaneously.

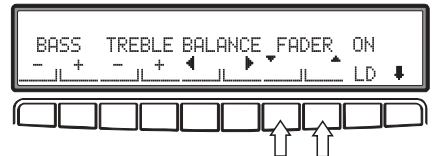

General Operation

Loudness on /off

Press  button and then multifunction button “LD”. The loudness will switch **ON** / **OFF**.

Loudness is switched off for AM, LW and SW wavebands.

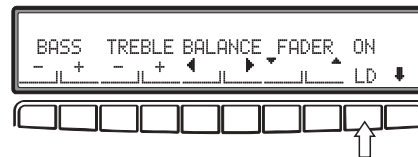

Linear adjustment

Press and hold  button until a signal tone sounds. The tone values for the set signal source (e.g. radio/FM) are set to an average value.

Press and hold  button until two signal tones sound. All tone values for the signal sources radio, CD/MD/TAPE and CDC/MDC are set to an average value.

Subwoofer output volume

Press multifunction button „↓“ in tone menu.

Then press multifunction button “-” or “+”. Set the desired subwoofer volume via both buttons.

The change in subwoofer volume to the currently set volume is shown in the display.

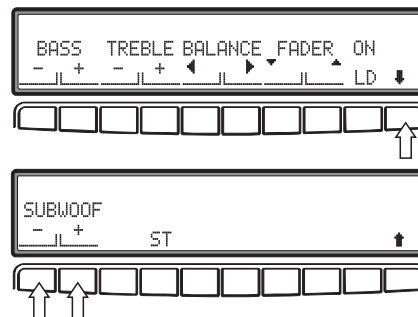

Selecting reception optimisation

Three different reception optimisation settings can be selected in order to suppress reception dependent interference and reflections.

Press multifunction button „↓“ in tone menu. Repeatedly press multifunction button “ST”, „AUT“ or “MON” in the tone menu until the desired optimisation is set.

AUT: (Auto) Setting for normal operation - i.e. the unit switches from stereo to mono and back depending upon reception location (provides the optimum setting for almost all reception areas).

ST: (Stereo) Setting for unusual reception situations - i.e. the unit is set permanently to stereo (e.g. for private radio stations in city areas)

MON: (Mono) Setting for reception conditions in which reflections constantly occur - i.e., the unit is set constantly to mono.

The setting is effective immediately after pressing the multifunction button “ST”, „AUT“ or “MON” and is also retained on switching off.

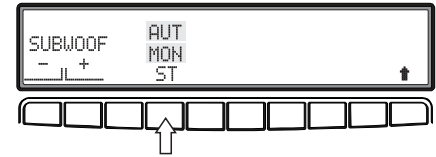

Radio Operation

Selecting the operating mode

Press function button 1. The operating modes **Tuner**, **MD** or **CD/TAPE** or **CD/MD changer** (for connected CD/MD changer) can be selected.

The last selected operating mode is set after the button is pressed for the first time. If the other operating modes are to be selected, press function button 1 quickly and repeatedly until the desired operating mode is selected.

Note: If you switch often between **FM** and **CDC**, first select **FM** and then through quick pressing **CDC**. Subsequently pressing the function button after a pause of more than 2 seconds allows switching to take place only between FM and CDC.

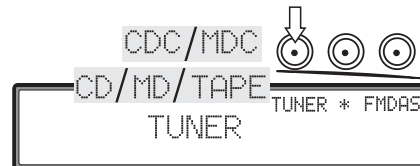

Selecting the waveband

Press the function button repeatedly until the desired waveband **FM DAS** (dynamic autostore), **FM STT** (FM station buttons), **AM**, **LW** or **SW** has been set.

When changing the waveband the last selected transmitter is set.



Switching on radio menu mode

Press function button 2 in radio mode. The radio menu mode is switched on and displayed. The unit switches back to the normal display if no button is pressed within the next 8 seconds.



Setting procedures for transmitter selection

The desired station can be selected via dynamic autostore, transmitter search, scan search, manual tuning, direct frequency entry and station buttons.

Dynamic autostore (FM DAS)

In FM DAS mode, all receivable stations are displayed above the multifunction buttons arranged according to alphabetical order.

The user menu (Page 85) explains how to set your favourite stations for selection according to alphabetical order.

Set the desired station by pressing the button directly below the abbreviated station designation. If the selected station broadcasts several programmes/regional programmes, a submenu is automatically displayed to select the desired programme. If a programme has previously been selected that belongs to the particular transmitter chain, the last stored programme entry will be automatically selected.

The symbol > means that the button can be pressed for displaying and selecting additional stations.

To indicate those stations not easily identified due to display of advertisement or news, the abbreviation L-1... L-Z (L = Local) is used, thus preventing constant switching in the lower display line. Selected stations of this type are indicated by a star (e.g. L*1).

When using the unit for the first time, or following interruption of the power supply, allow for a brief waiting period so that the receiver can evaluate the station signals. The display will appear incrementally as the evaluation progresses.



Radio Operation

FM transmitter search

Turn the right rotary control to the left/right. The radio searches in descending/ascending order, according to selected search mode.

To request the desired search mode in the user menu (also see page 83), refer to the setting information below:

- **FRQ** for **frequency search**. More information on Page 92.
- **NAM** for **name search**. More information on Page 92.
- **CHN** for **transmitter chain search**. More information on Page 92.

AM, LW, SW station search

Turn the right rotary control to the left/right within the desired waveband (AM, LW). The radio searches for reception frequencies in descending/ascending order of frequency.

Scan search

In the desired waveband (FM, AM or LW), press the right rotary control -  will be displayed. An automatic transmitter search is started. The first search is performed on an insensitive plane, all further searches on a sensitive plane. Receivable transmitters can be heard for 8 seconds. Press the right rotary control if the received program should be retained.

Note: In FM, the scan search will proceed according to the search mode that has been set.



Direct frequency entry for FM

Select radio menu mode. Then press multifunction button “MAN”.
Use the multifunction buttons to enter the desired frequency.
Only those numbers used for entry will be displayed.

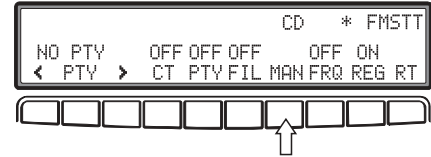

Direct frequency entry for AM, LW, SW

Select radio menu mode within the desired waveband. Use the multifunction buttons to enter the desired frequency.
Only those numbers used for entry will be displayed.

Programme type selection (PTY)

Select radio menu mode. Then use multifunction buttons “>” and “<” to select the desired PTY (also see page 93).

Note: Only those PTYs can be selected that are currently available.

Once a PTY has been selected, only those stations can be selected in FM DAS mode that are provided with this PTY.
By selecting **NO PTY**, all stations will be re-displayed in FM DAS mode.

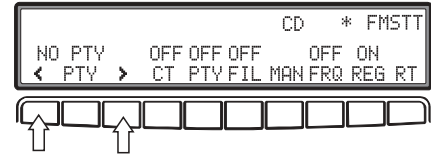

Switching PTY display on / off

Select radio menu mode. Then press multifunction button “PTY” to switch the PTY display (ON) or (OFF).
The PTY of the station being listened to will then appear on the right-hand side of the normal display.

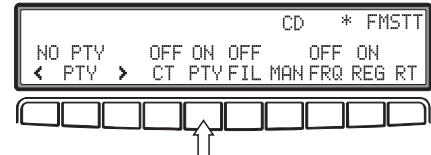

Radio Operation

Requesting/storing stations on FM STT

Storing: 27 frequencies or programmes can be stored on FM STT.

To store the desired station or programme, press and hold multifunction button “1 - 9” for 2 - 4 seconds.

Press multifunction button to access 10 - 27 of the available frequencies that can be stored.

The frequency is stored on the station button if the multifunction button is pressed for longer than 4 seconds (display **FIX**).

Request: Press multifunction button “1 - 9”. The stored transmitter is requested.

The stored frequency is set if the transmitter cannot be identified.

No diversity or programme identification is performed after request if only one frequency is stored on the multifunction button. **FIX** appears on the display.

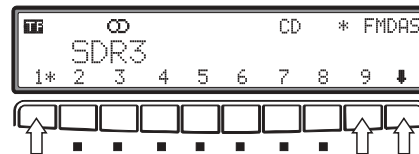

Requesting/storing AM, LW, SW stations

Request: Press multifunction button “1 - 0”. The stored transmitter is requested.

Store: 10 transmitters can be stored under station buttons. Search for the desired station and press the multifunction button until a signal tone sounds.

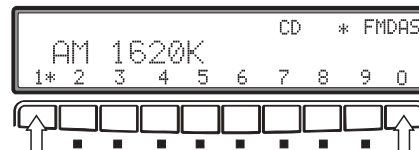

AM, LW, SW autostore

Select desired waveband. Select radio menu mode. Then press multifunction button “AS” repeatedly until **AS-SEEK** is displayed. The 10 transmitters with the best reception are stored under the station buttons in order of quality. The autostore storage plane is identified on the display by **AS**.

Select radio menu mode in order to quit the autostore storage plane. Then press multifunction button “AS”. The radio switches back to the station button plane.

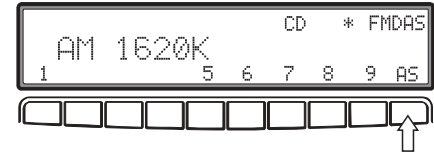

FM manual tuning

Select radio menu mode. Then press multifunction button “MAN”. Next turn right rotary control.

100 kHz tuning steps are performed. The function is quit if there is no further actuation within 8 seconds.

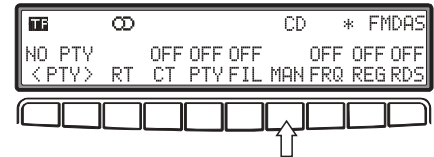

AM, LW, SW manual tuning

Select radio menu mode within the desired waveband and then turn the right rotary control.

9kHz (AM), 3kHz (LW) or 5kHz (SW) tuning steps are performed. The function is quit if there is no further actuation within 8 seconds.

Pressing the right rotary control switches to fine tuning (1kHz steps).

Radio Operation

Regionalisation

The RDS diversity function is independent of region. If the RDS diversity function should switch among various regional programmes with diverse broadcast contents, the special regional sub-programme must be selected directly.

A transmitter must first be selected in order to see if it broadcasts more than one regional programme.

Stations with additional regional transmitters are identified by a star (e.g. *4). Upon selection of one of these stations (e.g. *4) all receivable regional sub-programmes for this station will be displayed.

At this point it is possible to select the desired regional sub-programme (e.g. **BWK**).

If, despite RDS diversity function, the reception quality of a regional sub-programme is inferior, bear in mind that regional sub-programmes are transmitted for the most part over only a few frequencies. If the unit remains tuned to frequencies with better reception quality, there will be less drift.

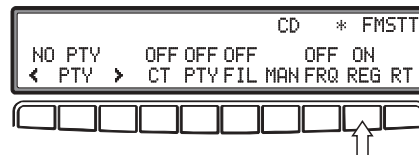
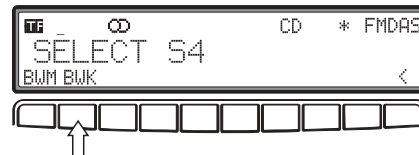

Switching frequency display on / off

Select radio menu mode. Then press multifunction button “FRQ” to switch frequency display (ON) or (OFF).

When the frequency display is on, the switched frequency of the selected RDS diversity transmitter is displayed.

If the frequency display is ON, the time display automatically switches OFF (also see page 70).

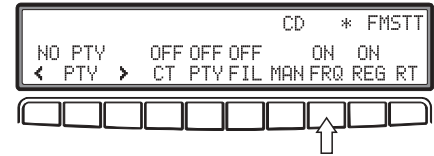

Switching radio text display on / off

Select FM radio menu mode. Then press multifunction button “RT” to switch on the radio text.

The car radio filters information transmitted by the station and displays it in the form of radio text.

Radio text cannot be displayed unless the selected station also transmits radio text.

Unfavourable reception conditions, including interference, can garble or even block a radio text display.

To quit the radio text function, press multifunction button “END”.

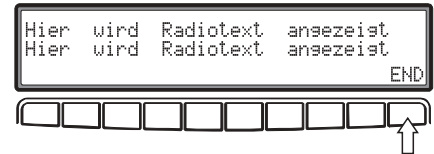
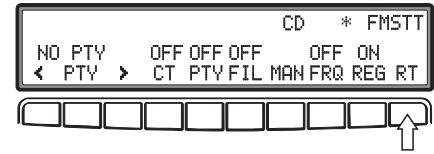

Important: Since information transmitted via radio text display varies constantly, we recommend tuning in the radio text only when the vehicle is stationary to avoid unnecessary distraction for the driver. This is a necessary precaution for accident prevention.

Radio Operation

Programme filtering

You have the option of filtering various stations from the FM DAS transmitter list.

First select FM radio menu mode. Then press multifunction button “**FIL**” to switch the filter (**ON**). Switch back to the normal display; press and hold the multifunction button below the station to be filtered until **Done** appears on the display. **Done** is preceded by **Set Filter:** and the name of the station to be filtered.

The filtered station will no longer appear on the normal display.

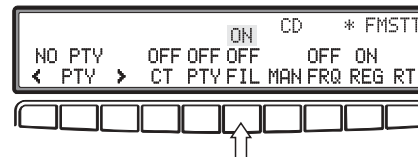
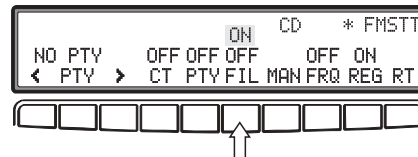

Deactivating the programme filter

Select FM radio menu mode. Then press multifunction button “**FIL**” to switch the filter (**OFF**).

When selecting a filtered station in normal display mode, **SDR3** will appear to indicate that the station has been filtered.

To deactivate a station filter, press the button under the station no longer to be filtered and hold until **Done** is displayed. **Done** is preceded by **Reset Filter** and the name of the station that had been filtered.

Traffic Program (TP)

If an RDS diversity station transmits TP announcements, you can have CD/MD/TAPE, CDC/MDC, AM, LW and SW operation interrupted and the transmitted TP announcements switched through. Moreover, you can listen to one FM station while having TP announcements switched through that are transmitted by another FM station.

There are two ways to select a TP station:

- **automatic tracking**
- **direct programming**

Automatic tracking transmits TP announcements over the FM station currently being listened to. If the selected FM station reception is of poor quality or cannot function as a TP transmitter, the unit applies specified criteria to search for a new TP transmitter.

Direct programming enables a TP transmitter to be programmed that is not the FM station being listened to. You can, for example, listen to one FM station while having TP announcements switched through that are transmitted by another FM station.

If the programmed TP transmitter reception becomes weak, the unit switches to automatic tracking until the programmed TP transmitter is receivable.

If an RDS transmitter is provided with a traffic programme, an inverse T will appear on the display.

If TP is activated, the currently selected TP transmitter will appear on the right-hand side of the display. In addition, an inverse TP will appear on the display to indicate the activated traffic programme.



Radio Operation

Activating/quitting the TP menu

Activating: Press and hold the **TP** button for longer than 2 seconds.

Quitting: Press and hold the **TP** button; otherwise, the TP menu will automatically disappear after 8 seconds if no further operations are performed.



Setting automatic tracking

Press multifunction button “TP” repeatedly in the TP menu until **ON** appears.

Important: If a TP transmitter has previously been directly programmed, it will once again be selected as TP transmitter.

Quitting the TP menu.

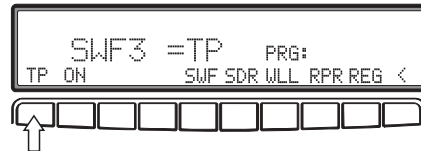

Setting/deleting direct programming

Activating the TP menu.

Setting: The station providing TP announcements can be directly selected by pressing one of the multifunction buttons.

For direct programming, set automatic tracking beforehand.

SDR3=TP, for example, indicates the currently activated TP transmitter.

Press **PRG: SDR3**, for example, to display the programmed TP transmitter.

Deleting: Press multifunction button “DEL” to delete the programmed TP transmitter and to set the unit to automatic tracking.

Quitting the TP menu.

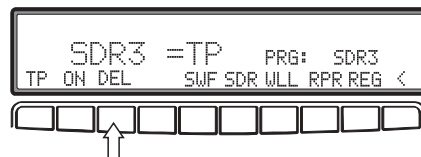
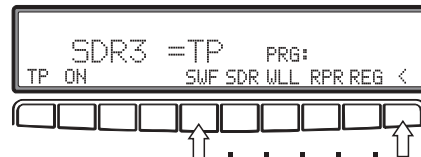
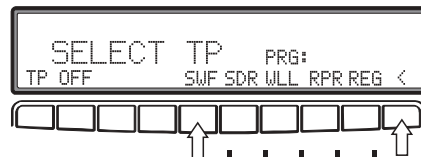

Switching off TP

Press and hold the **TP** button for longer than 2 seconds. Press multifunction button “**TP**” repeatedly in the TP menu until **OFF** and **SELECT TP** appears. TP is switched off after returning to normal display.

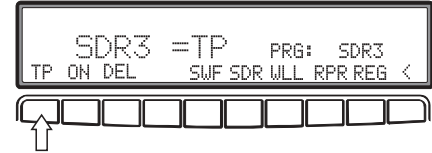

Mute function - switch on/off

After selection of a TP or EON transmitter, the mute function can be activated by pressing the **TP** button briefly. The prompt **TP INFO** appears. Thereafter, only traffic announcements are switched through. The mute function is cancelled by pressing the **TP** button again or by turning the volume control. If no TP transmitter is selected, **MUTE** is displayed on actuating the button **TP**. In MUTE no traffic announcements are switched through.



Interrupting TP announcements

Press the **TP** button during a TP announcement. The announcement being currently broadcast will be interrupted and the unit will automatically return to the previously selected mode.

TP announcement volume

The volume is adjusted during a TP announcement via the volume control. The adjusted volume will be stored and subsequent announcements will be automatically reset to the stored volume. It is not possible, however, for the TP announcement volume to be lower than the pre-set volume.

Radio Operation

Telephone mute function

The telephone characteristics can be set in the user menu (also see page 84) if a telephone system is installed in the vehicle and the mute function lead for the car telephone is connected to the car radio.

When set to **OFF**, the radio is switched to mute if a call is received.

When set to **ON**, telephone calls are connected through the radio unit if a call is received.

However, this is only possible if, in addition to the telephone, a handsfree unit with loudspeaker output is installed and connected to the radio. In both cases, **PHONE** is displayed.



Time request

Select radio menu mode in FM waveband. Then press and hold multifunction button “CT” until **ON** is displayed. The current time in hours and minutes will appear on the normal display. The accuracy of the displayed time depends on the correct time broadcast by the transmitter and received via RDS. If no time signal has been received, --:-- is displayed.

If the time is switched ON, the frequency display automatically switches OFF (also see page 65).

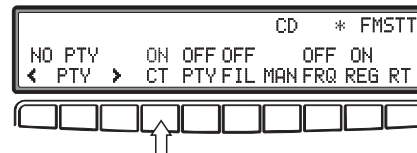

Cassettes - insert / eject

Press  button briefly; the display folds downwards and the cassette slot becomes visible. Push in cassette with tape-side to the right until it engages and press lightly. The cassette is drawn in automatically. Then fold the display up again.

The unit switches automatically to cassette operation. **TAPE 1** appears on the display.

If there is already a cassette in the cassette slot, press function button repeatedly until **TAPE** appears on the display.

In order to eject a cassette, press  button briefly; the display folds downwards and the cassette is ejected and can be removed. Then fold the display up again.

Attention : The cassette is not ejected when the unit is switched off but remains in the cassette slot.

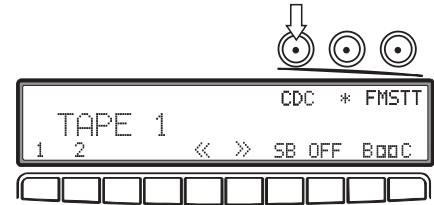

Track switching

The track is changed automatically at the end of the tape.

The tape track can be switched at any desired position by pressing briefly one of the multifunction buttons for track switching (**1** or **2**). The track currently playing is shown on the display.

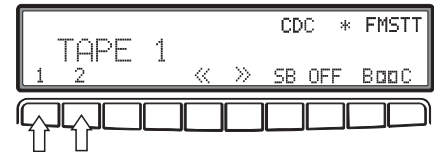

Radio operation during forward / rewind

During forward / rewind, the radio (FM) can be connected through by turning the volume control. Operation of the radio functions is, however, not possible.

Tape Operation

Fast forward / rewind

During cassette operation, fast forward / rewind can be activated using the multifunction buttons.

In order to cancel the function, press or turn the right rotary control, or press the track switching buttons or the fast forward / rewind buttons.

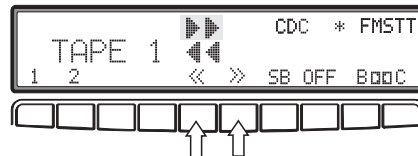

Music search - forwards / backwards

In order to activate the forward music search, turn the right rotary control to the right until the desired number of tracks to be skipped has been set.

In order to activate the backward music search, turn the right rotary control to the left until the desired number of tracks to be skipped has been set.

The beginning of a track can only be found if there is a pause of at least 4 seconds between tracks. In order to cancel the function, press or turn the right rotary control, or press the track switching buttons or the fast forward / rewind buttons.



Dolby NR

To play cassettes recorded with Dolby NR, press the multifunction buttons **B** or **C** repeatedly for the desired noise reduction mode (Dolby B or Dolby C).

A star is displayed alongside the Dolby noise reduction that has been set.

To quit the noise reduction function, press multifunction button **B** or **C** repeatedly until the star is no longer displayed.

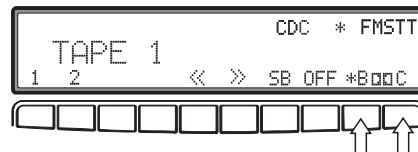

Skip blank

If skip blank is active, automatic forward is activated at blank tape sections which are longer than 10 to 15 seconds.

In order to activate the function, press the multifunction button “SB” repeatedly until **ON** or **OFF** is shown on the display.

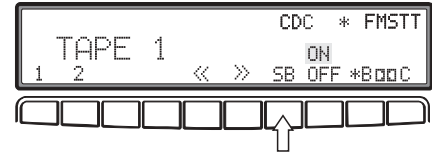

Scan search

Press the right rotary control to start the scan search.

SCAN appears on the display. Each track is played for approx. 10 seconds.

In order to cancel the function, press the track switching buttons or the fast forward / rewind buttons.



Cleaning the cassette mechanism

After a time, the reproduction quality of cassettes is reduced due to unavoidable dirt and dust deposits on the sound head. The drive components in the cassette mechanism also become dirty. For this reason the cassette mechanism should be cleaned from time to time. The prompt **CLEAN** appears on the display after each 30 hours running time.

Use a cleaning cassette suitable for reverse operation for this purpose. The cleaning cassette should be removed again after 30 seconds.



CD/MD Operation

Compact disc (CD) instructions

Sound interruptions may occur if the CD is dirty. In order to ensure optimum tone quality, please note the following:

- Always touch the CD at the edges only. Keep the disc clean and never touch the surface.
- Never stick anything to the CD.
- Protect the CDs against direct sunlight and from heat sources such as heaters etc.
- Before playing, clean the CD with a commercially available cleaning cloth, wiping from the centre outwards. Solvents such as petrol, thinners or other commercially available cleaners and anti-static sprays must not be used.

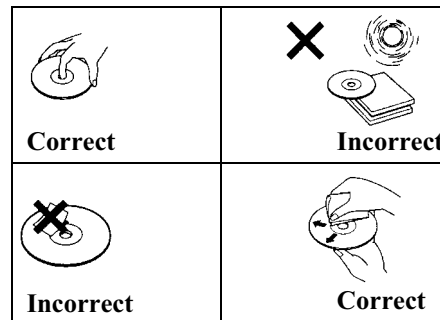

Insert / ejecting CDs/MDs

Press  button briefly; the display folds downwards and the CD/MD slot becomes visible. Insert the disc into the CD/MD slot with the printed side upwards. The unit pulls in the CD/MD automatically and begins to play the disc from the first track. Then fold the display up again.

After playing the last track, the unit automatically begins to play the first track of the CD/MD again.

If there is already a CD/MD in the slot, press function button 1 repeatedly until **CD** or **MD** appears on the display.

In order to eject a CD/MD, press the  button briefly; the display folds downwards and the CD/MD is ejected. Then remove the CD/MD. Then fold the display up again.

Important: The CD/MD is not ejected when the unit is switched off but remains in the slot.

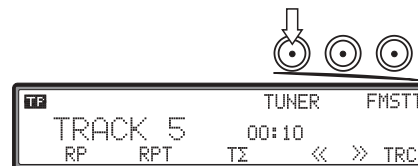

Skipping tracks - forwards / backwards

Turn right rotary control to right / left.

Through further turning of the right rotary control, several tracks can be skipped over in forward or backward directions. The device switches to the first track when the last track has been reached. Analogously, it switches from the last track to the first track.

If the track has been playing for longer than 10 seconds when the return function is triggered, the device returns to the beginning of the track.



Scan search

Press the right rotary control; **SC** appears on the display. All following CD/MD tracks are played for 10 seconds each. Press the rotary control again to terminate the scan search.



Fast forward / rewind

Fast forward (audible) is activated by pressing the multifunction button ">>" and fast rewind (audible) is activated by pressing the multifunction button "<<".

Fast forward / rewind is terminated by releasing the multifunction button.

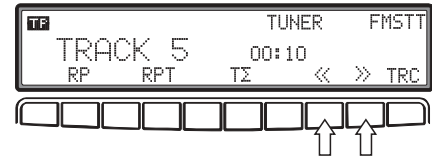

CD/MD Operation

Number of tracks and total playing time

By again pressing the multifunction button “TΣ”, the number of tracks and total playing time of the CD currently being played are displayed for approx. 10 seconds.

If an MD is being played, only the number of tracks is displayed.

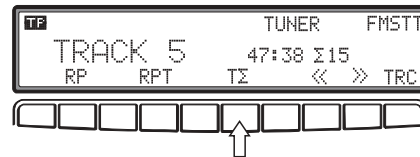

Random play

The random play is activated by pressing the multifunction button “RP”. The tracks of the current CD/MD are then played in random order. ⤴ appears on the display.

The random play function is terminated by repeated pressing of the multifunction button “RP”.

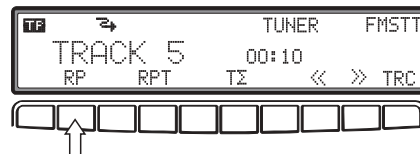

Replaying a track (repeat)

"Repeat track " is activated by pressing the multifunction button “RPT”. ⤴ appears on the display.

The "repeat track" function is terminated by repeatedly pressing the multifunction button “RPT”.

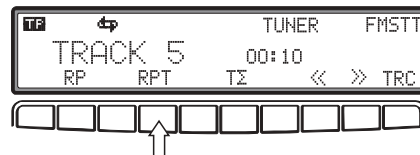

Direct track selection

The unit is switched to select mode by pressing the multifunction button “TRC”.

TRACK __ is displayed.

A track can be selected directly by using the multifunction buttons “1-0”. The unit switches back to CD menu mode if no buttons are actuated for approx. 8 seconds.

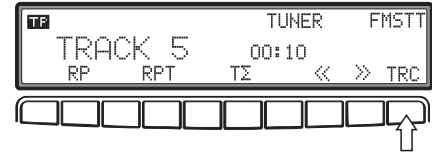

Temperature protection circuit

A temperature protection circuit is utilised in this unit in order to protect the laser diode against over heating.

When this protection circuit is activated, **TEMP** appears for 8 seconds and the unit reverts to radio mode.

After a cooling time has elapsed, Single CD operation can be resumed. If it is still too hot, the unit will revert to the signal source that had been previously set.



CD/MD Changer Operation

Operational readiness of CD/MD changer

A CD/MD changer connected to the auto audio unit is ready for operation when there are CDs/MDs loaded. Close the sliding tray after loading. Further operation is performed via the car radio control panel.

CD magazine - load / unload

In order to remove the CD magazine, open the sliding cover on the changer and press the eject button. The magazine is ejected and can be removed.

When inserting CDs in the magazine, please note imprint on magazine.

Important: Incorrectly inserted CDs will not be played.

Note: In order to ensure the fastest possible CD change, the magazine should be fully loaded from compartment 1.

Playing CDs/MDs

Press function button 1 repeatedly until the CD/MD changer operation is switched on. The last CD/MD that was played is played from the position at which it was left before switching off.

CDs/MDs can be selected via the multifunction buttons. During the selection time **CD X LOADING** or **MD X LOADING** is displayed. Subsequently, the magazine compartment number and the number of the current track for the selected CD/MD are displayed.

If no CD/MD is present in the selected magazine compartment (e.g. compartment 2), **NO CD 2** or **NO MD 2** appears briefly on the display.

After playing the last track of a CD/MD, the next CD/MD in the magazine is automatically selected and played.

For further operations see CD Operation (page 23):

- "Compact disc (CD) instructions" page 74
- "Skipping tracks - forwards / backwards" page 75
- "Scan search" page 75
- "Fast forward / rewind" page 75*
- "Number of tracks and total playing time" page 76*
- "Random play" page 76*
- "Direct track selection" page 77*

Important: For the points marked with *, function button 2 must be pressed before selection, in order to access the submenu.

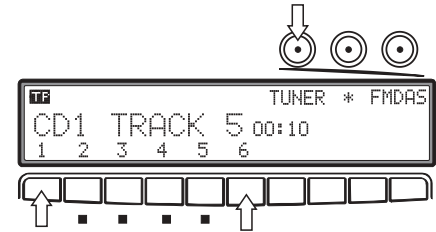

CD/MD Changer Operation

Naming a CD

Press function button 2 in CDC mode. Then press multifunction button “NAM”. The input menu appears on the display.

In order to name a CD or revise an existing name, press the function button above ”EDIT“ (function button 1).

Select the desired alpha characters using the multifunction buttons to the left and right of the abbreviation **ABC**. Or turn the right rotary control to the left or right.

To select the character position to be revised, use the multifunction buttons to the left and right of the abbreviation **POS** (flashing editing symbol). To advance one character position, press the right rotary control.

A maximum of 8 characters can be entered.

To store the name, press the function button above ”OK“.

To delete an existing name, press the function button above “DEL” in the input menu. Next select the name to be deleted using the multifunction buttons to the left and right of the abbreviation **DEL**. Or turn the right rotary control to the left or right.

Delete the name by pressing and holding the multifunction button “DEL” for longer than two seconds.

To quit the function, press the function button above ”OK“.

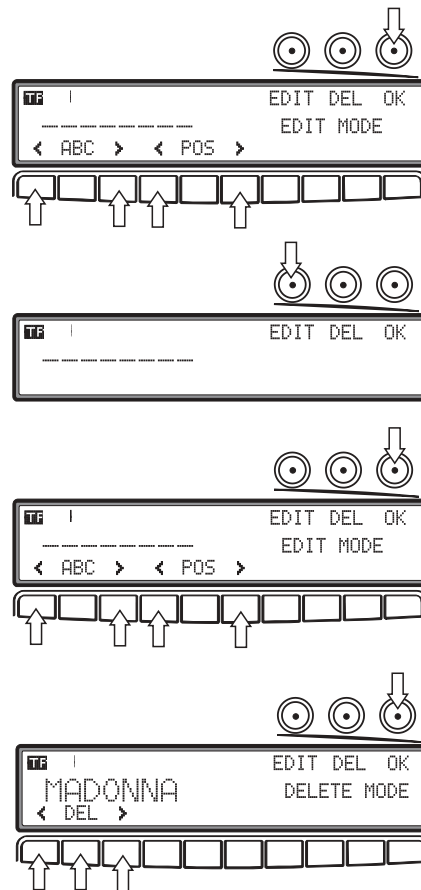

CD title filtering

Press function button 2 in CDC mode.

To filter the current CD title, briefly press the multifunction button “**FIL**”. **FIL** appears above the multifunction button, which means the filter is activated. Next press and hold the multifunction button “**FIL**” for longer than 2 seconds. **Set Filter** will appear briefly and **FIL** will appear in the uppermost display line to indicate the filter that has been set for this title.

To deactivate the filter, briefly press the multifunction button “**FIL**” in order to switch off the filter function first. (The display changes from **FIL** to **FIL**). Then select the previously filtered title. The set filter for the selected title will be indicated by **FIL** in the uppermost display line. Next press and hold the multifunction button “**FIL**” for longer than 2 seconds. **Reset Filter** appears briefly. The filter for this title has now been deactivated.

Important: The filter function can be activated only if a name has been stored for the selected CD.

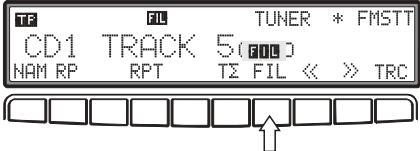

User Menu

Requesting/quitting user menu

After requesting the user menu, the following basic settings can be selected according to your personal preference.

- US** - user memory
- SEK** - search mode
- GAL** - speed-dependent volume control
- TEL** - telephone characteristics
- DRV** - LHD / RHD setting
- FAV** - favourite station settings
- AUX** - aux input setting
- LCD** - display setting (not for 4625)
- COL** - display colour setting (not for 4625)
- END** - quit user menu

The user menu is requested by pressing and holding function button 2 for longer than 4 seconds. The accompanying menu appears on the display. In order to quit the user menu, press multifunction button **END**.

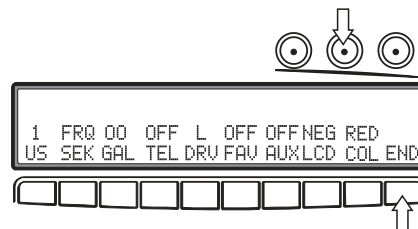

User memory (US)

Request the user menu. Press multifunction button "US" to select the relevant user (1, 2 or 3).

Both tone settings for the individual tone sources and the GAL setting when the unit was switched off, are stored in each user memory.



Setting the search mode (SEK)

Request the user menu. Press multifunction button “SEK” to select **FRQ**, **NAM** or **CHN**.

- FRQ** - Frequency search
- NAM** - Name search
- CHN** - Transmitter chain search



GAL setting

The GAL is a car radio control circuit, which automatically adjusts the car radio volume according to vehicle speed. This results in compensation of the driving noise produced at higher speeds.

Request the user menu. Press multifunction button “GAL” to select from **00** to **15**. With the GAL setting, the start of volume adjustment can be specified according to vehicle speed.

The setting is stored automatically.



Explanation of terms:

- 00** - no volume control
- 01** - Volume adjustment is initiated at low speed
- 15** - Volume adjustment is initiated at high speed

User Menu

Telephone mute characteristics (TEL)

If a telephone system with handsfree unit is installed in the vehicle, the telephone conversation can be conducted via the car radio system. Thus, installation of the normally required additional loudspeaker is not necessary. It is essential that the signal cables (AF - telephone input and earth - telephone input) are connected to the car radio (see page 94).

For selection, request user menu. Press multifunction button “**TEL**” to select **ON** or **OFF**.

- OFF** - Telephone mute mode
- ON** - Telephone conversation via car radio

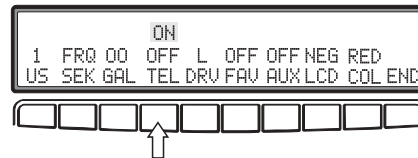

Setting right-hand or left-hand drive (DRV)

If a telephone system with handsfree unit is installed the telephone conversation is conducted via one loudspeaker side. The relevant loudspeaker side (LHD / RHD) is selected using the DRV setting.

For selection, request user menu. Press multifunction button “**DRV**” to select **L** (left-hand drive) or **R** (right-hand drive). The setting is stored automatically.

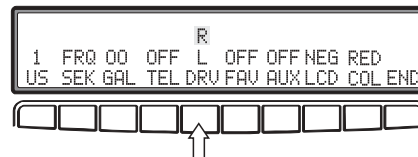

(COL) display colour setting (not for 4625)

This setting is used to choose between two illumination colours.

For selection, request user menu. Press multifunction button “**DRV**” to select between **RED** (red) and **YEL**(yellow). The setting is stored automatically.



Favourite station settings (FAV)

The favourite station setting allows you to program the stations in FM DAS according to listening preference rather than alphabetical order. For example, if the user selects a 2nd-level FM DAS menu station with a less powerful receiving signal, the station will be stored in 1st position in the FM DAS menu regardless of the receiving signal strength.

For selection, request user menu. Press multifunction button “FAV” to select **ON** or **OFF**. The setting is stored automatically.

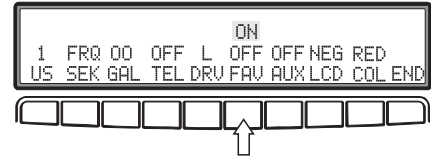

AUX input (AUX)

This can be switched to **ON** if no CD/MD changer is connected. An external unit (Discman, Walkman, etc.) can then be operated via the CD changer AF connections.

For selection, request user menu. Press multifunction button “AUX” to select between **ON** or **OFF**. The setting is stored automatically.

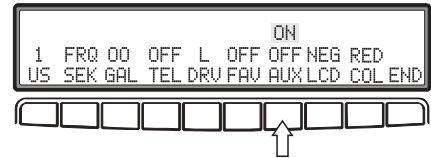

User Menu

Display setting (LCD) (not for 4625)

The display setting allows you to select among three different display versions.

- Negative display (**NEG**)
- Positive display (**POS**)
- Automatic display (**AUT**) - the display will appear negative or positive depending on vehicle illumination.

For selection, request user menu. Press multifunction button “**LCD**” to select between **NEG** (negative), **POS** (positive) or **AUT** (automatic). The setting is stored automatically.



Service menu - request / quit

By repeatedly pressing the right rotary control, the following information can be requested in the service menu.

- TYPE** - display of model number
- SN** - display of serial number
- DATE** - display of software status
- CDW RESET** - reset triggering for CDW or MDW (if present)
- GAL** - display of current GAL adjustment
- SCD** - data from CD drive (if present)

In order to select the service menu, press **TP** button repeatedly (within 8 seconds of switching on) until **BECKER 1** is displayed.

On selection of menu function **RESET**, CD/MD changer reset is first performed after actuation of multifunction button “**RES**”.

The unit must be switched off in order to quit the service menu.



Remote Control (option)

Operation with infra-red remote control

There are two planes for remote control operation. The two planes are accessed by pressing the * button.

Available at both planes:

- ON button - switch on / off
- BD button - select waveband
- MODE button - select operating mode

Available at first plane:

- Button 2 / ^ - increase volume
- Button 8 / v - decrease volume
- Button 5/SC - scan function according to operating mode
- Button ⏮/4 - downward search or track skip downwards
- Button 6 / ⏭ - upward search or track skip upwards

Available at the second plane after pressing the * button:

- Buttons 0 - 9 - station button selection

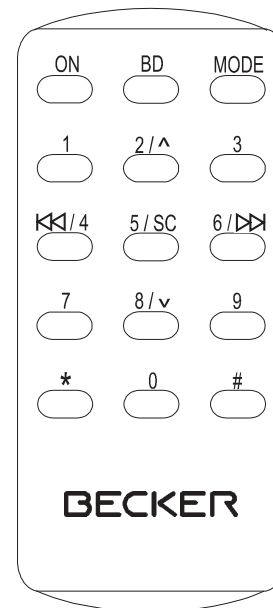

Connection Instructions

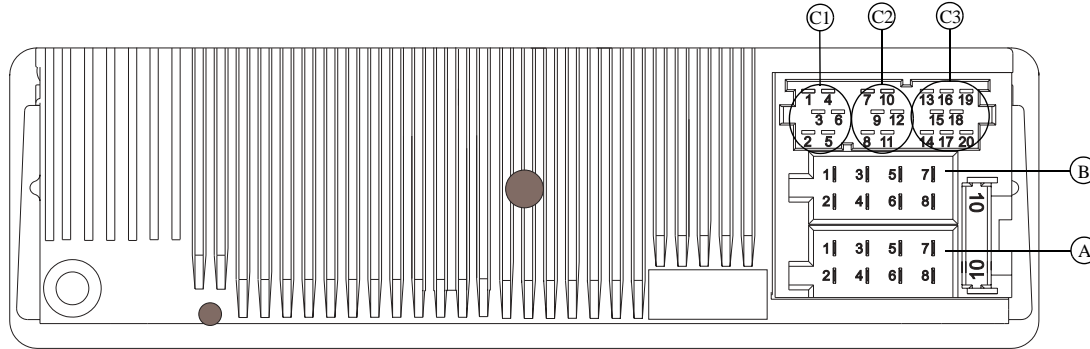

Warning! Terminal 30 and terminal 15 must always be connected separately, otherwise an excessive current consumption occurs when the unit is switched off. Connection socket A is not the same for all vehicle types. Therefore, always measure voltages before installation.

Socket A

- 1 Speed dependent volume control
- 2 not assigned
- 3 Telephone mute / clearing function
- 4 Permanent positive (terminal 30)
- 5 Control output for automatic aerial / amplifier
- 6 Illumination (terminal 58)
- 7 Switched positive (terminal 15)
- 8 Earth (terminal 31)

Socket B

- 1 Loudspeaker rear right +
- 2 Loudspeaker rear right -
- 3 Loudspeaker front right +
- 4 Loudspeaker front right -
- 5 Loudspeaker front left +

- 6 Loudspeaker front left -
- 7 Loudspeaker rear left +
- 8 Loudspeaker rear left -

Socket C1

- 1 LineOut rear left
- 2 LineOut rear right
- 3 AF earth
- 4 LineOut front links
- 5 LineOut front right
- 6 LineOut Subwoofer

Socket C2

- 7-12 Special connection for Becker CD changer / Sony MD changer

Socket C3

- 13 AF telephone input
- 14 Earth - telephone input
- 15-17 Special connection for Becker CD changer / Sony MD changer
- 18 CD AF earth (AUX)
- 19 CD AF left (AUX)
- 20 CD AF right (AUX)

Removal / Installation Guide

A universal bracket for DIN installation slots is integrated into this car radio. An installation frame is not required. The unit is inserted into the installation slot and secured using the slides supplied.

Complete the electrical connections. Then push the unit into the installation slot. Subsequently, push the slides into the apertures in the front of the unit to the first detent position (illustration A). Now lock the radio by pulling both slides, as shown in illustration B. Subsequently, remove the slides.

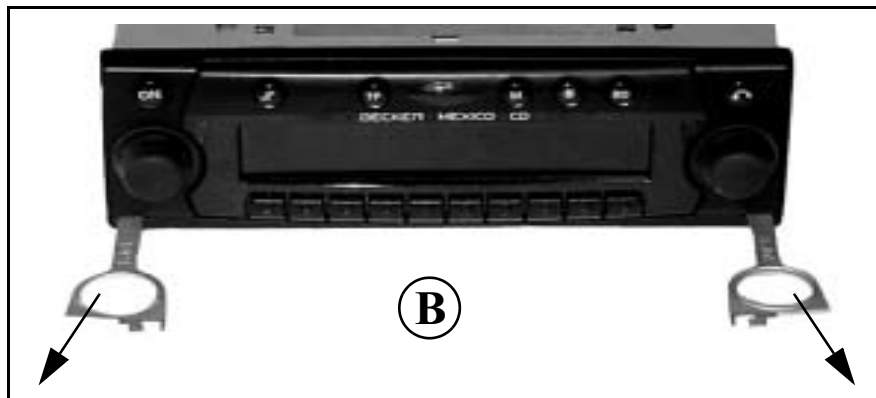
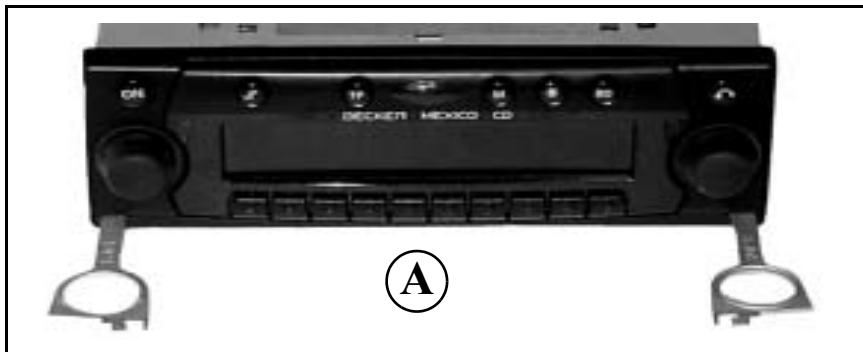

Removal / Installation Guide

For removal, the unit must first be unlocked. For this purpose, push in both slides to the second detent position, as shown in illustration A. Subsequently, withdraw the unit with both slides (illustration C). Then remove the slides by pressing the springs on the right and left sides of the unit.

If the unit has been installed in another vehicle, the unit's springs may have to be adjusted before installation. To adjust the springs, push in the slides as shown in illustration D and then adjust as shown in illustration E (press the slide lightly in direction 1 and simultaneously move the slide in direction 2).

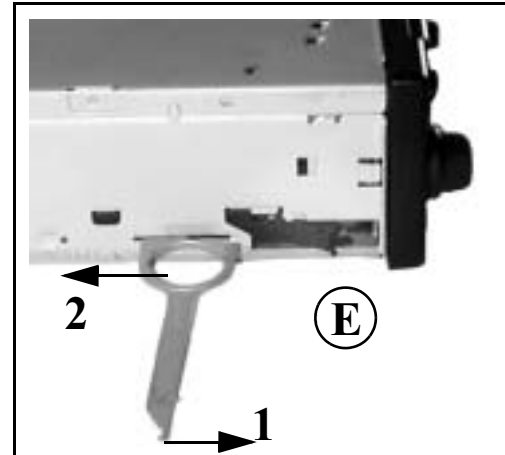
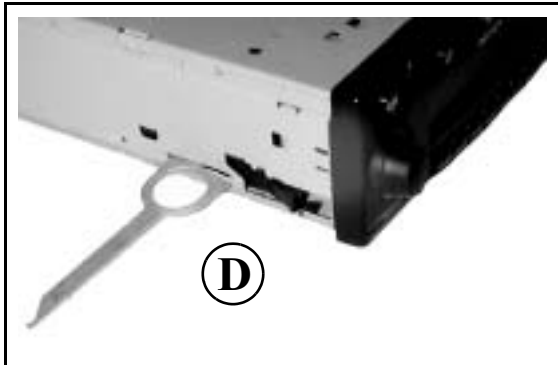

General Instructions

Frequency search

In frequency search mode, the receivable frequencies are searched for in descending/ascending order of frequency. Each receivable frequency is set. Tuning steps of 100 kHz are used for the search.

Name search

In name search mode, all receivable and identifiable RDS programmes in FM can be selected in descending or ascending alphabetical order.

Transmitter chain search

In the transmitter chain search mode, all receivable and identifiable RDS programmes in FM can be selected according the transmitter chains to which they belong.

RDS SYSTEM

This car radio is capable of receiving RDS signals (RDS = Radio - Data - System) in the VHF range. RDS is a technique which enables the transmission of inaudible additional information in the VHF broadcasting range. This means that the transmitter broadcasts information which can be evaluated by the car radio.

PTY (Program Type)

Specific types of program, such as e.g. sport, pop music, classical music etc., can be selected using the PTY function.

The PTY is broadcast by the RDS transmitter, provided that the transmitter is equipped with this function. The selected transmitter program type can be displayed or a search of a specific PTY transmitter can be performed.

Examples of program types:

NEWS	News services	POP M	Pop music
AFFAIRS	Politics and current affairs	ROCK M	Rock music
INFO	Special word programme	SCIENCE	Science
EDUCATE	Learning and further education	LIGHT M	Easy listening
DRAMA	Radio plays and literature	CLASSICS	Classical music
CULTURE	Culture, church, society	EASY M	Musical entertainment
VARIED	Light entertainment	SPORT	Sport
OTHER M	Special music programmes	WEATHER	Weather reports
FINANCE	Financial information	CHILDPRG	Childrens' programmes
SOCIAL	Social reports	RELIGION	Religious reports
PHONE IN	Interviews	TRAVEL	Travel reports
LEISURE	Leisure time reports	JAZZ	Jazz music
COUNTRY	Country music	NATION M	Traditional music
OLDIES	Oldies	FOLK	Folk music
DOCUMENT	Documentary	NO PTY	No programme type

Technical Data

Wavebands	: FM 87.5 MHz - 108 MHz AM 531 kHz - 1620 kHz LW 153 kHz - 282 kHz SW 5800 kHz - 6250 kHz
Frequency range	: 50 Hz - 14 kHz for TAPE operation 20 Hz - 20 kHz for CD/MD operation 30 Hz - 15 kHz for FM 50 Hz - 2.5 kHz for AM, LW, SW
Output power	: 4 x 18 Watt
Line cross section	: min. 0.75 mm ²
Loudspeaker impedance	: min. 4 Ω
Line out	: 4 x analogue line out (V _a max 3V _{eff} at 10 kΩ)
GAL	: In order to utilise the GAL, a square wave voltage with an amplitude of +4 V - +12 V relative to earth, must be available from the electronic speedometer of the vehicle. The adjustment is performed in 7 steps of 2.5 dB.
Aerial	: Impedance 50 Ω
AF telephone input	: Max. input voltage 8 V (if interference occurs, a commercially available 1 : 1 transformer should be connected into the signal cable).
AUX input	: 16 kΩ input impedance, max. input voltage 1.7 V _{eff}
Telephone mute	: Low active level < 2 Volt
Supply voltage	: 12 Volt
CD/MD connection	: The Becker CD changer Silverstone (2660 or 2630), or the Sony MD changers MDX 60 and MDX 61 can be connected.
Playable CDs	: Only CDs which conform to DIN EN 60908 may be used. The use of 8 cm CDs with adapter is not recommended.

NOTICE

Dear listener !

According to current EU guidelines, any person may operate this radio receiver.

This unit conforms to the current valid European or harmonised national regulations. The designation is your guarantee of conformance to the applicable specifications concerning electromagnetic compatibility for the unit. This means that interference affecting other electrical/electronic devices caused by your unit, as well as interfering influences on your unit from other electrical/electronic devices, can be largely prevented.

Current designations are:

- **CE symbol** for issue according to European guideline 89/336/EEC.
- **e - symbol** according to European motor vehicle EMC guideline 95/54/EU, also permits operation in motor vehicles (classes M, N and O) which received their type approval after 1st January 1996



021364